

TABLE OF CONTENTS	Page
IMPORTANT NOTICE.....	2
RESTRICTIONS ON USE.....	3
PRODUCT CONFORMITY.....	4
1 SATELLINE-2ASC DATA MODEMS	5
1.1 RADIO DATA MODEM.....	5
1.2 RS-232 PIN CONNECTIONS	6
1.3 LED-INDICATORS	7
1.4 TECHNICAL SPECIFICATIONS.....	8
2 ASYNCHRONOUS DATA TRANSMISSION.....	10
2.1 ASYNCHRONOUS CHARACTERS	10
2.2 DATA SPEED	10
2.3 TRANSMISSION	10
2.4 RECEPTION.....	11
2.5 DELAYS DURING DATA TRANSMISSION.....	12
2.5.1 Delays on radio channel.....	12
3 PROGRAMMING THE SATELLINE-2ASC.....	13
3.1 CHANGING THE SETTINGS BY USING TERMINAL PROGRAM.....	13
3.1.1 Changing the radio frequency.....	14
3.1.2 Changing the serial port settings	14
3.1.3 Modification of handshaking functions	15
3.1.4. Changing the RSSI threshold value	16
3.1.5 Restoring factory settings	16
3.1.6 Saving modified setting into the permanent memory.....	17
4 PLANNING A RADIO MODEM NETWORK.....	18
4.1 FACTORS AFFECTING QUALITY AND DISTANCE OF THE RADIO CONNECTION.....	18
4.2 RADIO FIELD STRENGTH	19
5 INSTALLATION.....	20
5.1 RS-232 INTERFACE	21
5.2 SUPPLY OF CURRENT	22
5.3 MOUNTING THE ANTENNA	23
6 EQUIPMENT.....	25
6.1 THE CONNECTION OF ANTENNAS TO RADIO MODEMS	25
6.1.1 Hand portable equipment.....	25
6.1.2 Equipment installed in vehicles	25
6.1.3 Base station	26
6.2 CABLES.....	26
6.2.1 RF cables	26
6.2.2 Interface cables	26
7 CHECK LIST.....	27

Appendices

1. The timing diagram of RS-232 interface of SATELLINE-2ASc radio modems
2. SATELLINE-2ASc RSSI curve

IMPORTANT NOTICE

All rights to this manual are owned solely by SATEL OY (referred to in this manual as SATEL). All rights reserved. The copying of this manual, without the written permission from the owner, of the rights by printing, copying, recording, or by any other means or the full or partial translation of the manual to any other language including all programming languages using any electrical, mechanical, magnetic, optical, manual or other methods or devices is forbidden.

SATEL reserves the right to change the technical specifications or functions of its products or to discontinue the manufacture of any of its products, or to discontinue the support of any of its products without any written announcement. SateL therefore its customers to ensure that the information at their disposal is valid.

SATEL software and programs are delivered "as is". The manufacturer does not grant any kind of warranty, including guarantees, on suitability and applicability to a certain application. Under no circumstances is the manufacturer or the developer of a program responsible for any possible damages caused by the use of a program. The names of the programs as well as all copyrights relating to the programs are the sole property of SATEL. Any transfer, licensing to a third party, leasing, renting, transportation, copying, editing, translating, modifying into another programming language or reverse engineering for any intent is forbidden without the written consent of SATEL.

SATEL PRODUCTS HAVE NOT BEEN DESIGNED, INTENDED NOR INSPECTED TO BE USED IN ANY LIFE SUPPORT RELATED DEVICE OR SYSTEM RELATED FUNCTION NOR AS A PART OF ANY OTHER CRITICAL SYSTEM AND ARE GRANTED NO FUNCTIONAL WARRANTY IF THEY ARE USED IN ANY OF THE APPLICATIONS MENTIONED.

Salo, FINLAND 2009

RESTRICTIONS ON USE

SATELLINE-2ASc radio modems have been designed to operate on frequency ranges, the exact use of which differs from one region and/or country to another. The user of a radio modem must take care that the said device is not operated without the permission of the local authorities on frequencies other than those specifically reserved and intended for use without a specific permit.

SATELLINE-2ASc is allowed to be used in the following countries, either on licence free channels or on channels where the operation requires a licence. More detailed information is available at the local frequency management authority.

Countries*: AT, AU, BE, BG, HR, DK, EE, FI, FR, DE, GR, HK, HU, IS, IE, IT, LV, LT, LU, NL, NO, PL, RU, RO, SG, SK, ES, SE, CH, TR and GB.

* codes of the countries follow the ISO 3166-1-Alpha-2 standard.

PRODUCT CONFORMITY

Hereby, SATEL Oy, declares that this SATELLINE-2ASc radio modem is in compliance with the essential requirements and other relevant provisions of Directive 1999/5/EC. Therefore the equipment is labelled with the following CE-marking.

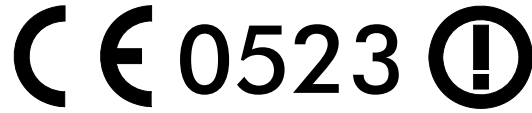

 **DECLARATION of CONFORMITY**

In Accordance with
1999/5/EC Directive

of the European Parliament and of the Council of 9 March 1999 on radio equipment and telecommunications terminal equipment and the mutual recognition of their conformity

Doc No: SATEL-DC/RTTE/024

Manufacturer: SATEL Oy

Address: POB 142, (Meriniitynkatu 17)
24101 Salo
Finland

Product: SATELLINE-2ASxE/125 Radio Modem
SATELLINE-2ASxE/200 Radio Modem
SATELLINE-2ASxE/250 Radio Modem
SATELLINE-2ASc Radio Modem, variant of SATELLINE-2ASxE

Notified Body Opinion: according to: Annex IV of R&TTE Directive
Document Nr: FIC0700019
Issued by: Telecommunications Administration Centre
Dated On: 2nd of July 2002
Notified Body Nr. 0523

We, the manufacturer of the above mentioned products, hereby declare that these products conform to the essential requirements of the European Union directive 1999/5/EC. This Declaration of Conformity is based on the following documents:

Doc. No	Type of Product	Test Specification	Laboratory / Date of Issue
TL 990276	-2ASxE/125	ETS 300 113	EMCEC / Espoo 17.09.1999
TL 990312	-2ASxE/200	ETS 300 113	EMCEC / Espoo 04.11.1999
TL 990267	-2ASxE/250	ETS 300 113	EMCEC / Espoo 22.09.1999
TL 1000482	-2ASxE/250	EN 300 220-1	EMCEC / Espoo 12.05.2000
TL 980003	-2ASxE	ETS 300 279	EMCEC / Espoo 26.02.1998
200216221	-2ASxE	IEC 60950	NEMKO / Espoo 23.04.2002

Salo on the 27th of January, 2003.

Pekka Ayya
Managing Director



Satel Oy, P.O.Box 142, FIN-24101 Salo, Finland
Street: Meriniitynkatu 17, FIN-24100 Salo, Finland
Tel: +358 2 777 7890, Fax: +358 2 777 7810, E-mail: info@satel.fi
www.satel.fi

1 SATELLINE-2ASc DATA MODEMS

This user guide is for SATELLINE-2ASc radio modems.

1.1 Radio Data Modem

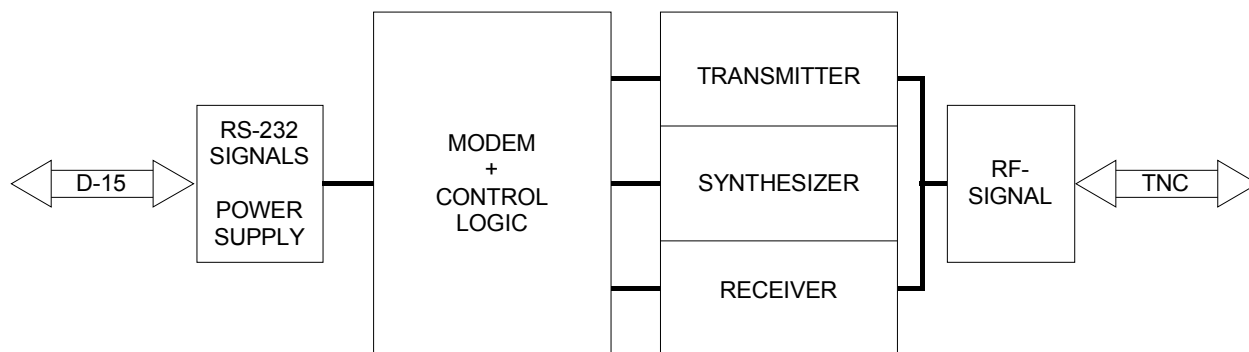

Fig. 1. SATELLINE-2ASc radio modem

The **SATELLINE-2ASc** radio data modem consists of a 450 MHz transceiver and a modem board, housed in a compact resistant aluminium enclosure. It has a RS-232 interface that allows easy connection to a variety of data networks.

The **SATELLINE-2ASc** transceiver board's function is based on the synthesised radio technique. The frequency stability is good and also permits channels to be configured.

Data transmission over a radio network is very similar to its cabled counterpart, the main difference being that with radio it is half duplex, and therefore timing delays must be considered when planning a system. In addition basic rules of radio system design related to antennas, cables, possible radio interference etc. must be followed.

Typical applications of radio modems are :

- Replacing a cable in situations where installation of such a cable is difficult, expensive or even impossible.
- Data transmissions between mobile or portable terminals
- Wireless alarm transmission
- Telemetry
- Remote control
- Transferring text to displays
- For use with Global Positioning System (GPS)

By using SATELLINE-2ASc radio data modems it is easy to install both point-to-point or point-to-multipoint connections. With its transmit power level at 1 W distances from 2 to 40 km can be achieved depending on topographical conditions and antenna locations. Country specific laws of radio communication must always be followed and responsibility for this lies with the user.

1.2 RS-232 Pin Connections

D-connector Pin	Line	SD	Operation
1	DTR	IN	Data Terminal Ready, ON/OFF switch of the modem "0" (0 V...-12 V), "1" (+5 V...+12V)
2	CD	OUT	Carrier Detect, indicates a signal or interference on the radio channel exceeding the sensitivity level of the modem
3	-	-	Reserved for future usage
4	NC		NC
5	RSSI	OUT	Receiving signal strength indicator (starts approximately from 0.5 V and goes up to 5 V)
6	CTS	OUT	Clear to send , indicates when the radio modem is clear to receive data via the RS-interface
7, 8	GND	-	Power Ground, the negative pole of the operating voltage and the signal ground
9	RD	OUT	Receive Data
10	DSR	OUT	Data Set Ready, indicates that the radio modem is switched ON
11	TD	IN	Transmit Data
12	PROG	IN	Data (NC) / Programming mode by connecting the modem to the ground (GND)
13	RTS	IN	Request to Send, gives radio modem a request to send, starts the transmitter (answer by CTS line)
14, 15	VB	IN	Supply Voltage positive pole +9 ... +30 Vdc

SD = Signal direction from radio data modem

IN = Input OUT= Output NC= No Connection

1.3 LED-indicators

There are five (5) LED-indicators on the front panel of the radio modem, and they give an indication of the status of the serial port and the radio interface:

LED	Indication	OFF	Red
RTS	RTS-line (D-connector pin 13) status	Inactive	Active
CTS	CTS-line (D-connector pin 6) status	Inactive	Active
TD	Radio modem is receiving data via serial port	No data	Data
RD	Radio modem is sending data via serial port	No data	Data
CD	Radio (D-connector pin 2) status	No signal	Data / noise on the radio channel

NOTE! SATELLINE-2ASc does not have a separate power LED. To verify that the modem is ON there are two options:

- if the RTS/CTS handshaking is OFF, the RTS LED can be used as a power LED by connecting the RTS pin (13) to the RTS pin of the terminal equipment (DTE).
- if the RTS/CTS handshaking is ON the only way to verify that the radio modem is ON is to activate RTS line, which starts also the transmitter or to check the CD LED while the radio modem receives a radio message.

1.4 Technical Specifications

SATELLINE-2ASc

SATELLINE-2ASc complies with the following international standards:
EN 300 220-1 (radio standard) and ETS 300 683 (EMC standard)

TRANSCEIVER

Frequency Range	380...470 MHz
Channel Spacing	25 kHz, 20 kHz
Number of Channels	80, 100
Frequency Stability	< ± 1.5 kHz
Method of Modulation	FSK

Transmitter

Carrier Power	10 mW ... 1 W (+30 dBm) / 50 Ω (factory set)
Carrier Power Stability	+ 2 dB / - 3 dB
Adjacent Channel Power	< 200 nW
Spurious Radiations	EN 300 220-1

Receiver

Sensitivity	-110 ... -115 dBm (BER < 10 E-3) *Note
Co-channel rejection	> - 8 dB
Adjacent channel selectivity	> 70 dB
Intermodulation attenuation	> 65 dB
Spurious radiations	< 2 nW

MODEM

Interface	RS-232
Interface Connector	D15 connector, female
Data Speed on 25 kHz	300 - 4800 bit/s
Data Speed on 20 kHz	300 - 2400 bit/s
Modulating Signal	Manchester-coded NRZ
Data Formats	Asynchronous data: 10 or 11 bits

GENERAL

Operating Voltage	+ 9 ... + 30 Vdc
Current Consumption	When DTR is "0": 0.05 VA When DTR is "1": Receiving: 2.5 VA Transmitting: 6.6 VA
Antenna Connector	TNC, 50 ohm, female
Size H x W x D	137 x 67 x 29 mm
Installation plate	130 x 63 x 1 mm
Weight	250 g
Temperature Range	- 25 °C...+ 55 °C

*Note: Depending on data speed

Labelling information:

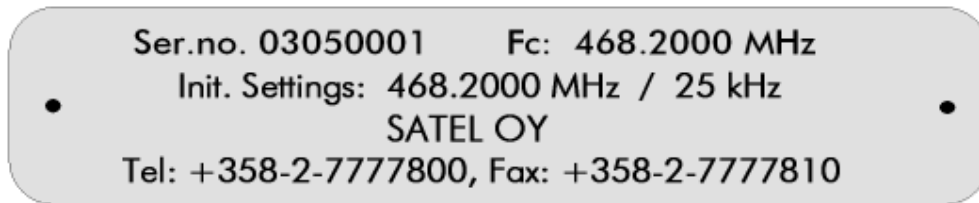

- Serial number (year+ week + manufacture number)
- Frequency, center frequency, tuning range +/- 1 MHz
- Initial settings: Frequency / channel spacing
- Manufacturer's contact information

2 ASYNCHRONOUS DATA TRANSMISSION

2.1 Asynchronous Characters

Data characters can be transmitted either in 10 or 11 bits, or in 8 or 9 bit data characters between the start and stop bits respectively. Characters are formatted in accordance with the ANSI standard asynchronous characters. The radio data modem transfers parity bits as such. Data settings can be changed in the programming mode by user. Please see chapter 3.

The composition of a character is shown below.

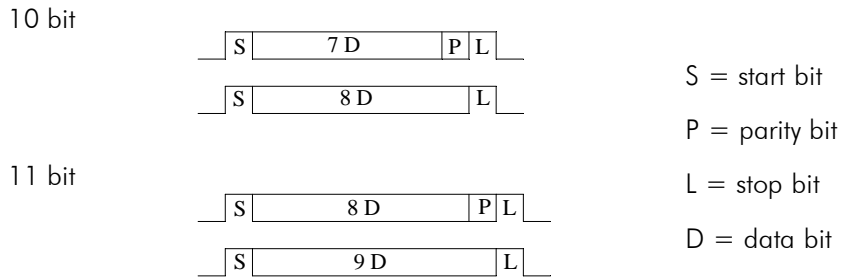

NOTE! The length of the character from the data terminal equipment must correspond to that of the radio modem.

2.2 Data Speed

The data speed of the radio modem can be set to 300, 600, 1200, 2400 or 4800 bits/s at the factory. The data speed is hardware configurable parameter. Later change of it requires submitting the modem to SATEL service.

2.3 Transmission

There are two different methods of initiating data transmission:

- 1 Data on TD line, no need to use handshaking
- 2 Transmission based on a special RTS/CTS handshaking (SATELLINE-1AS / 2AS compatibility)

The first method is typically used – terminal device sends the data on the serial port TD line. The radio modem receives the data from TD line and starts the radio transmission. In this case the status of the RTS line is ignored. CTS indicates when the radio modem is ready to receive data from the terminal device (DTE).

The second method involves the use of a special RTS/CTS handshaking. It is used when replacing or expanding the existing systems built up with SATELLINE-1AS / 2AS radio modems which operate at 2400 or 4800 bps. In order to transmit, the RTS line must be first set ON by the terminal device. The radio modem responds by setting the CTS line ON. After that the terminal device sends the data on TD line. Finally, after the data the terminal device must set the RTS line OFF.

The radio modem does not buffer the data from the terminal device while it is receiving the data from the air i.e. the data on the serial interface must be half-duplex also.

2.4 Reception

The radio modem is ready to receive data when the supply voltage is switched on and the DTR line is in the "ON" state. The reception is not possible while transmitting data, due to the half-duplex operation of the radio modem.

The radio modem receives data from the air and sends it on the RD line. In addition, the change in state of the CD line also allows the terminal equipment to detect if the radio channel is occupied.

2.5 Delays during data transmission

Transmitting data over a radio link always adds delays which may affect to the timing of a system. These delays are:

- Wake-up time DTR OFF/ON 450 ms
- RTS/CTS delay 10 ms
- RS-interface turn around time
 - RTS/CTS handshaking OFF 11 ms
 - RTS/CTS handshaking ON 23 ms

2.5.1 Delays on radio channel

Delay from the end of transmission to the end of reception on the serial interface:

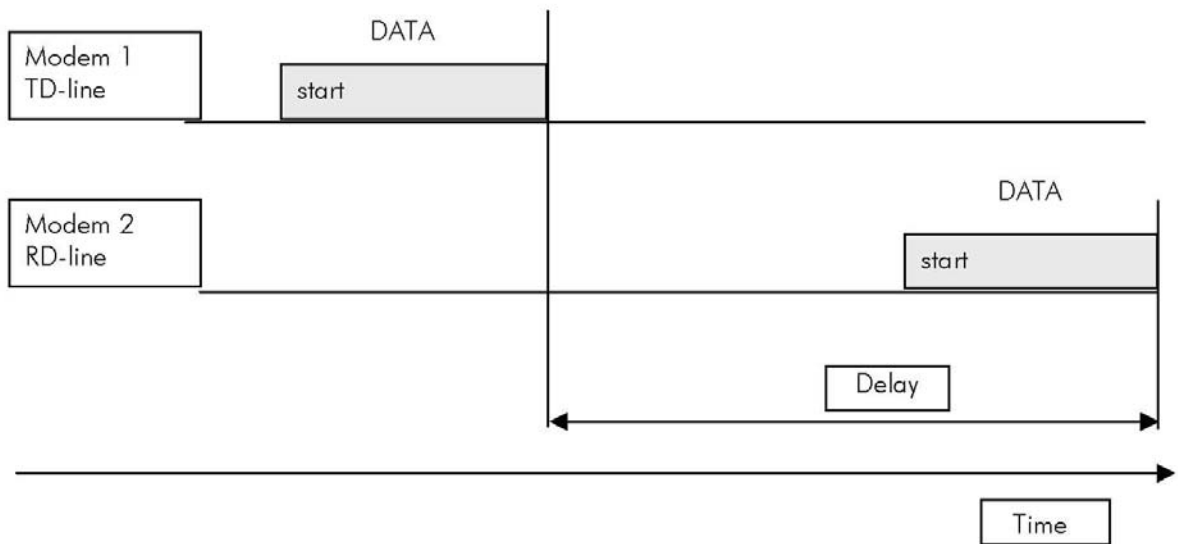

Number of bytes sent

Bps	1	10	100	500
2400	64	101	468	2120
4800	43	61	246	1080

Delay is milliseconds with 10 % margin.

3 PROGRAMMING THE SATELLINE-2ASc

The settings of the SATELLINE-2ASc radio modem can be changed easily. When pin 12 (PROG) is connected to ground (GND), the radio data modem enters the Programming Mode. This is easiest done by using ARS-1F interface adapter provided by SATEL Oy or your nearest distributor.

In the Programming Mode the settings of the serial port are always 9600 bps, N, 8, 1. In this mode the settings of SATELLINE-2ASc can be changed in the way described on the following pages.

3.1 Changing the settings by using terminal program

Connect the radio data modem to a terminal or a PC running a suitable terminal program such as SaTerm. Check that the terminal settings are 9600 bps, 8, N, 1. Connect pin 12 (PROG) of the D-connector to ground (GND). The radio data modem sends a screen menu to the terminal:

```

-----
-
          ***** SATEL, SATELLINE - 2ASc *****
                SW Versi on vx.yz
-----
-
Current settings
-----
Max frequency      469.5000 MHz
Center frequency   468.5000 MHz
Min frequency      467.5000 MHz
Channel spacing    25 kHz

1) Radio frequency      468.5000 MHz
2) Serial port          4800 bps 10 bits
3) RTS/CTS handshaki ng off
4) RSSI threshold      -115 dBm
F) Restore factory settings
E) EXIT and save settings
Q) QUIT wi thout savi ng

```

3.1.1 Changing the radio frequency

The radio channel of the modem can be set in menu "1". In the example below the frequency is changed (468.5000 MHz → 468.2000 MHz).

```

Enter selection > 1

Radio frequency setup
-----
Enter new frequency or ESC to cancel: 468.2000
    
```

The selected frequency must be within the specified limits, normally ± 1 MHz from the center frequency. The channel is given as a numerical value.

NOTE!
 Adjustment of the active radio channel of the radio modem to frequencies other than those allocated and / or allowed by local authorities is strictly forbidden. Use or intended use of forbidden frequencies may lead to prosecution and penalties. SATEL is not responsible for any illegal use practiced with any devices manufactured and / or sold by SATEL and is not liable to pay any damages or compensation caused by such illegal use.

3.1.2 Changing the serial port settings

The serial port settings can be set in menu "2". In the following example the number of data bits (10 → 11) is changed. Please note that data speed is not software programmable, but requires hardware modifications.

```

Enter selection > 2

Port setup
-----
   Data speed      4800 bps
1) Character length 10 bits

Enter selection or ESC to cancel > 1

Data bits setup
-----
1) 10 bits
2) 11 bits

Enter selection or ESC to cancel > 2
    
```

Now the modification of the example has been performed and the value is displayed:

```

Port setup
-----
  Data speed      4800 bps
1) Character length 11 bits
Enter selection or ESC to cancel >
    
```

The settings of the serial port must be modified to correspond with the settings of the terminal device that is to be connected to the radio modem.

```

NOTE!
It should be noted that switching the radio modem into Programming Mode by
connecting the PROG-pin (pin 12 of the D-connector) to ground (GND) will
change the settings of the serial port to 9600, 8, N, 1 automatically irrespective of
the serial port DATA-mode settings.
    
```

3.1.3 Modification of handshaking functions

The handshaking function can be set on by selecting the option from menu "3". In the following example the handshaking is set on.

```

Enter selection > 3
-----
RTS/CTS handshaking setup
-----
1) On
2) Off
Enter selection or ESC to cancel > 1
    
```

Now the modification of example has been performed and the menu is displayed:

```

-----
-
          ***** SATEL, SATELLINE - 2ASc *****
                    SW Version v0.00
-----
-
Current settings
-----
  Max frequency      469.2000 MHz
  Center frequency   468.2000 MHz
  Min frequency      467.2000 MHz
  Channel spacing    25 kHz

1) Radio frequency   468.2000 MHz
2) Serial port       4800 bps 11 bits
3) RTS/CTS handshaking on
4) RSSI threshold    -115 dBm
F) Restore factory settings
E) EXIT and save settings
Q) QUIT without saving
    
```

3.1.4. Changing the RSSI threshold value

The RSSI threshold value can be changed by selecting the main menu selection "4". In the following example the RSSI threshold value is set to be -110 dBm. The value can be choosed between -115 ... -80 dBm.

```

RSSI threshold setup
-----
Enter new RSSI or ESC to cancel: -110
    
```

Now the modification of example has been performed and the menu is displayed:

```

-----
-
          ***** SATEL, SATELLINE - 2ASc *****
                    SW Versi on v0.00
-----
-
Current settings
-----
Max frequency      469.2000 MHz
Center frequency   468.2000 MHz
Min frequency      467.2000 MHz
Channel spacing    25 kHz

1) Radio frequency      468.2000 MHz
2) Serial port          4800 bps 11 bits
3) RTS/CTS handshaking on
4) RSSI threshold      -110 dBm
F) Restore factory settings
E) EXIT and save settings
Q) QUIT without saving
    
```

3.1.5 Restoring factory settings

Selecting main menu selection "F" can restore factory settings.

```

Enter selection > F
-----
Restore factory settings
-----
1) Yes
2) Cancel

Enter selection or ESC to cancel >
    
```

Restoring is confirmed by pressing "1" (Yes) or cancelled by pressing "2" (Cancel). Also the pressing of ESC button at any point in the procedure will return the display to the previous (next higher) menu level without restoring factory settings.

3.1.6 Saving modified setting into the permanent memory

All modified settings must be saved into the permamnet non-volatile memory of the radio modem before switching out of the Programming Mode. Selecting the main menu selection "E" automatically saves the settings:

Enter selecti on > E
Configurati on saved! Please turn off program mode swi tch!

NOTE! To switgh the radio modem back into Data Transfer Mode from the Programming Mode the PROG-pin of the D-connector (D-15 pin 12) must be disconnected from ground (GND).
--

4 PLANNING A RADIO MODEM NETWORK

4.1 Factors affecting quality and distance of the radio connection

- power of radio transmitter
- sensitivity of radio receiver
- tolerance of spurious radiations of the radio modulating signal
- amplification of transmitting and receiving antennas
- antenna cable rejection
- height
- natural obstacles
- interference caused by other radio frequencies

The transmitter power of the base model of SATELLINE-2ASc is 1 W and sensitivity of receiver more than -115 dBm. Thus in a flat area and in free space with a 1/4 wave antenna (antenna amplification 1dBi) and an antenna height of 1 m, communications from 3 km to 4 km can be achieved. Distances may be considerably shorter in situations where there are metallic walls or other material inhibiting the propagation of radio waves.

Raising the height of the antennas can often solve problems caused by natural obstacles such as trees when used over long distances. A ten-fold increase in distance can be achieved with the use of amplifying antennas (however, local regulations regarding transmission power must be checked and adhered to). Frequent topographical variations over long distances may require that at least one of the antennas needs to be raised to a height of between 10 and 20 m.

Should the placement of the antenna at the base station be more than 10 m from the modem, it would be necessary to use a low loss cable (< 0.7 dB /10m) in order not to impair the antenna amplification.

Should the base station antenna need to be placed near other radio transmitter antennas (eg. NMT, GSM etc.), an antenna filter should be added between the modem and the antenna.

The SATELLINE-2ASc radio data modem operates in the 450 MHz band where interference caused by human beings is quite low. Long distance interference need not to be taken into account even in special weather conditions.

The SATELLINE-2ASc eradicates normal levels of interference that occur. However, exceptionally high levels of interference can break through the safeguards and thus cause errors on transmission. In mobile vehicle applications the range of operation can be increased by dividing the transmitted data into smaller blocks (< 100 characters) and by retransmitting defected blocks.

A sufficient safety margin can be obtained by testing communications using an extra 6 dB attenuator at the antenna connection or with slightly less effective antennas than those to be used in the final system. SaTerm test program (available free from your distributor) can be used in the communications testing. If there is a need to measure RSSI signal during the SaTerm test transmission, a message long enough must be used.

4.2 Radio field strength

A successful radio transmission depends essentially on the radio field. Where field strength is over a certain level the operational results are very good. Below this level, a few dB marginal areas may occur in which errors begin to be generated by noise and interference, which will eventually lead to loss of connection.

Whilst in an open space, the field strength is at its optimum level - although it will still be reduced by distance. It must also be remembered that one open space has different environmental and external factors to another and that the effects on transmission quality must be taken into account when planning the system.

Ground, ground contours and buildings cause attenuation (loss of energy through absorption) and reflections of radio waves. Buildings reflect radio waves and therefore the effects of attenuation are not as acute when transmission is over a short distance.

However, the reflected waves will suffer a loss in power once they travel over a certain distance, this means that they combine with the direct radio waves and interact in either weakening or strengthening the signal respectively. In reality attenuation can even occur at 40 dB which is very sharp and the effect on the 450 MHz frequency is about 35 cm difference.

Please note that the RSSI tolerance is ± 10 dB when using the RSSI signal of the modem to define the field strength. See appendices 3 and 4.

5 INSTALLATION

The radio modem must be installed with the installation accessories supplied with the radio modem

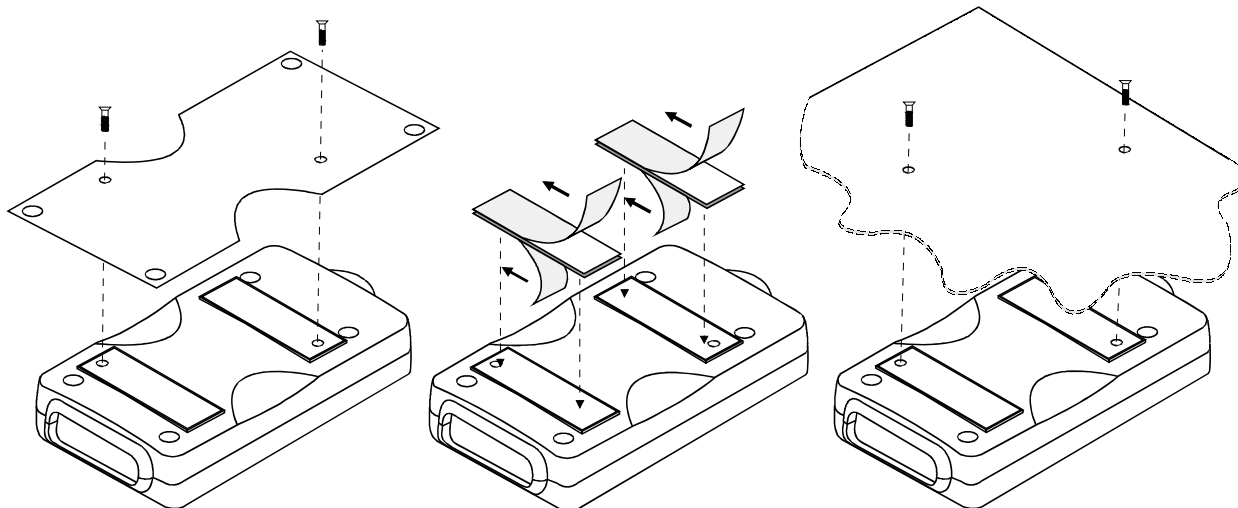

1. By using the installation plate, that should be fastened on the back of the radio modem. The installation plate can be mounted using the holes provided on installation plate .

2. By using the velcro-type tape supplied with the radio modem.

3. By mounting the radio modem directly on the customer's equipment .

NOTE ! When choosing the place of mounting, please check that water can not get inside the radio modem. It is not recommended that the radio modem should be mounted on a powerfully vibrating foundation. The attachment should be lessened with help of a resilient material.

The radio modem fulfils the technical specifications regarding temperature range $-25\text{ }^{\circ}\text{C} \dots +55\text{ }^{\circ}\text{C}$. The radio modem operates also outside this temperature range but does not necessarily fulfil all specified requirements.

5.1 RS-232 Interface

The radio modem is connected to terminal via RS-232 interface. A typical connection where all handshaking lines are used is according to the figure below.

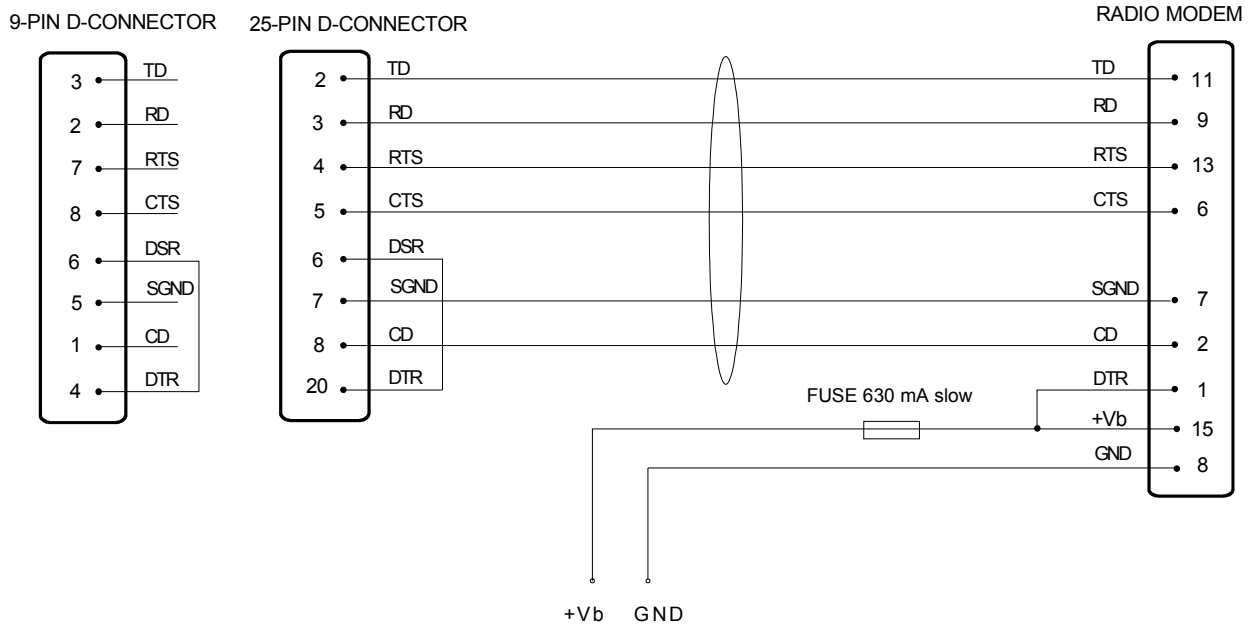

In some systems the radio modem is connected to another data transmission equipment (modem). The lines should in this case be connected across according to the picture below.

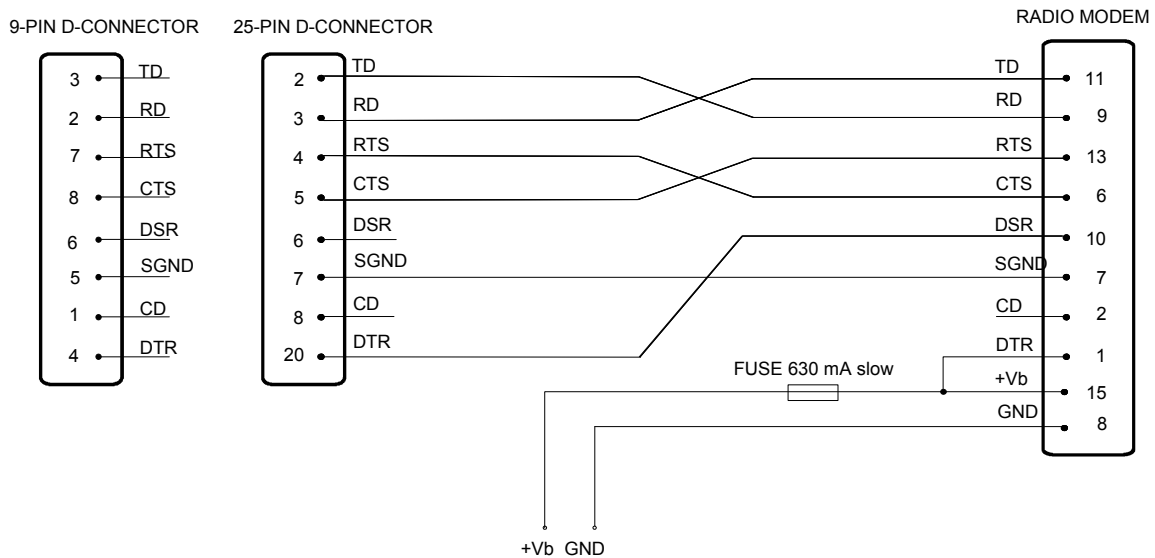

5.2 Supply of current

The nominal voltage of SATELLINE-2ASc radio modems is +9 ... +30 Vdc. The positive pole of the operating voltage is connected to the pins 14 and 15 of the D15 connector and to the negative pole (GND) to the pins 7 and 8.

The DTR line in position "1" can be used as an ON/OFF switch. In this case the logical state "1" (+5...+12 V) corresponds to ON and "0" (0 V...-12 V) to OFF.

The current consumption of SATELLINE-2ASc is between 150 and 730 mA. In systems where models SATELLINE-1AS or -2AS are to be changed to models SATELLINE-2ASc, the current supply has to be checked.

Especially in portable applications the DTR line of the radio modem should be switched to position "0" when possible. In this situation the current consumption is approximately 3 mA (SATELLINE-2ASc). In mobile use, the radio modem is required to have a direct connection to the main vehicle battery in order to avoid additional interference.

NOTE POWER SUPPLY !

Even if the nominal output current of the power supply does not exceed the limit it may become temporarily be unstable as the current consumption changes e.g. when the power amplifier is started. Commercially produced power supplies are usually supplied with the capability of handling over capacity situations to meet peak demands, this feature may not be present in self-built units and therefore may affect the performance of the modems.

Even if the nominal output current is considerably higher than the current consumption of the radio modem, the voltage varies according to the changes of the current consumption of the radio modem. This weakens the function of the radio modem or prohibits it totally.

Supply current should be controlled in situations where the distance is short, or the radio field strength is sufficient but the connection fails or the number of faulty packets is big. Quick changes in voltage can not be measured with a multimeter as they may only last 0.5 ms. Therefore possible situations with under voltage should be surveyed with an oscilloscope. To ensure a reliable operation of the radio modem the acceptable variation is below 1 V from the stable level and continuous oscillation below 50 mV.

NOTE! Whenever connecting RS-232 interface cables to equipment, the power of the equipment MUST FIRST BE SWITCHED OFF.

5.3 Mounting the antenna

The operation of radio communication over great distances or in otherwise severe conditions is dependent on antennas and their mounting. Antennas, antenna cables and terminal adapters, should always have a gold plated connector, as connectors of poor quality oxidate and increase the attenuation over a period of time. Appropriate connectors and correct tools must always be used when mounting antennas. One should also check that both the antenna, and possible fitting elements, can cope with both weather and environmental contamination.

The metal-free zone around small antennas should be at least 1/2 m and big antennas more than 5 m. The metal-free zone should be greater than 10 m around a relay antenna combination. This means that if a large network of radio modems is to be installed, the most suitable location for the antenna is at the highest point of the building, or even mounted on a radio mast. If a mast is used, the antenna can be installed using a side-installation up to 2 ...3 m away from the mast itself.

When mounting the antenna possible sources of interference must be taken into account, these include:

- mobile phone network base stations
- local telephone network base stations
- television transmitters
- radio links
- other radio modem networks
- PC equipment (within a radius of about 5 m from the antenna)

When ordering antennas please note that they have been tuned to a certain frequency range. Simple antennas and those made of stacked yagis, are relatively wide band. The frequency range of the antenna becomes narrower the more elements there are in a yagi.

Accessibility to allow for testing and service of the system must be considered during installation. This can often be achieved by using a reasonable length of good quality, low loss, antenna cable in order that the modem can be mounted in a sensible, accessible location.

The antenna cable should be chosen according to the length bearing in mind the following recommendations:

Length	Type	Attenuation
< 5 m	RG58	3.0 dB/10 m/450 MHz
5 ... 20 m	RG213	1.5 dB/10 m/450 MHz
> 20 m	AirCom+	0.8 dB/10 m/450 MHz *)

*) AirCom+ cable is partly air insulated thus an absolutely airtight connection between the cable and the connector is achieved.

In great distances when the antennas are in optimal positions, a 6 dB power marginal is adequate. Since the connection is built on the reflection and/or the knife-edge diffraction the path, loss can vary by up to 20 dB depending on the weather conditions. In this case, a short test can give a too positive result of the quality of the connection. Thus the height of the antennas and topographical obstacles must be surveyed with great care. From time to time an attenuating connection can be used if the data transmission protocol is well prepared for this and the data transmission that occasionally slows down does not cause any problems to the process.

Vertical polarised systems (i.e. antenna elements are located in vertical position) are often used in radio systems. This is particularly recommended in a system using a base station and sub-stations. The radio modem antenna cannot be mounted on the same level with the other sub-station antennas in the same building. The best way to distinguish from the other local antennas is by mounting the antennas as far above one another as possible. The best result is generally obtained when all the antennas are on the same mast. With an extra ground plane between the antennas more distinction can be obtained between the antennas in the mast.

Horizontal polarisation can be used in data transmission between two points. With the polarisation attenuation more distinction is obtained in the vertical polarisation interference. The influence of the directional patterns of the antennas must, however, be taken into consideration. If a distinction to another interfering antenna is wanted with the horizontal polarised antennas there must be a good attenuation of the back lobe. In addition to this the interfering radiator should be situated behind the antenna.

Where an omnidirectional antenna is not required, a directional antenna should be used instead. An example of this is being a two-element yagi to be used in fixed, external installation. As the antenna amplification increases the setting of the direction of the antenna demands accuracy.

The base stations in high places should be supplied with between 4 and 6 degree band-pass filters. Please note that the higher the antenna, the larger the broadcast area. However if the antenna is installed too high the base station may suffer from interference.

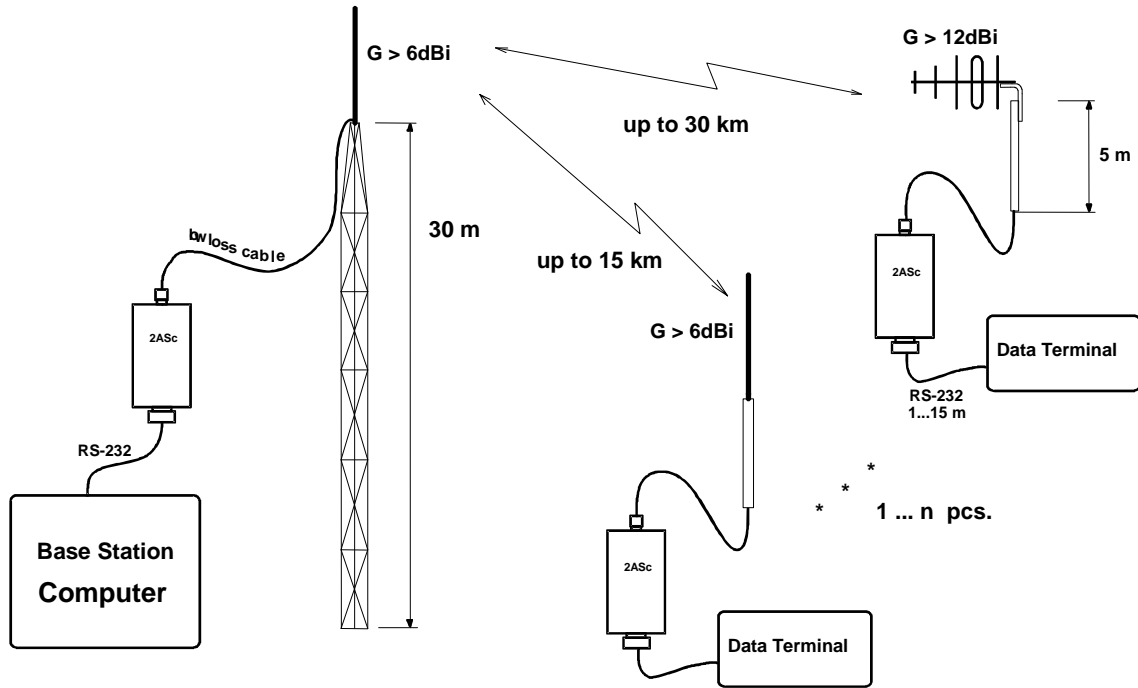

Example of an antenna installation: By use of amplifying antennas and by installing antennas in a high location, long distances can be achieved with the SATELLINE-2ASC.

6 EQUIPMENT

6.1 The connection of antennas to radio modems

Recommended antenna types are as follows:

6.1.1 Hand portable equipment

1/4 wave antenna (wave length on 450 MHz is about 70 cm)

Helix antenna

The antennas are mounted directly on to the antenna connector (TNC) at the top of the radio modem.

6.1.2 Equipment installed in vehicles

1/4-wave antenna

1/2 wave antenna

Ideally the antenna should be installed vertically and it should have at least 0.5 m of open space surrounding it. In a small system 1/4 wave antenna is adequate. There should be a ground plane below the antenna (truck bonnet or roof). In weak conditions a 1/2 wave antenna is the most suitable. It can be mounted at the top of a pipe, as this provides it with

as much open space as possible. In places where the antenna cannot be connected directly to the TNC a 50 ohm coaxial cable must be used to provide the link between the TNC and the antenna.

6.1.3 Base station

omnidirectional (1/4, 1/2 or 5/8 wave antenna)

directional (yagi or corner reflecting antenna)

The antenna should be installed in an upright position. The exact location of the antenna depends on a number of factors from system size to physical ground contours. As a general rule, the antenna for a base station should be located at the highest point in the most central location of the system.

Alternatively, the base station antenna can be mounted inside a building, providing that the walls of the building do not contain metal.

6.2 Cables

NOTE ! Please check that the contact area of cable connectors is gold plated and that the connectors used are reliable. Ageing connectors of poor quality oxidate easily and cause malfunction of the system.

6.2.1 RF cables

If the antenna cable is shorter than 5 m, a good quality 50 ohm RF cable can be used (e.g. RG58). If a longer cable is required a low loss RF cable is highly recommended. A standard cable comprises of 50 ohm RG58 cable in lengths of 1 m (CRF-1) and 5 m (CRF-5).

6.2.2 Interface cables

When planning the location of the radio modem, it must be noted that the maximum length of a RS-232 cable is 15 m and the cable must be shielded. The maximum length of the power supply cable is 2 m. Standard cables can be supplied with either a 25 pin connector (CRS-1F or CRS-1M, F=female, M=male) or with a 9 pin connector (CRS-2F or CRS-2M). The length of the cables are 2 m and they contain both interface and power supply cables.

7 CHECK LIST

When installing and configuring a radio data modem following points should be considered:

1. Before connecting the RS-232 interface to equipment always check that the operating voltage is switched off.
2. Consider the exact location of the equipment for optimum results
 - Place the antenna in a free space as far as possible from any source of interference
 - Do not place the modem on a strongly vibrating surface
 - Do not place the modem in direct sun light or high humidity
3. The capacity and stability of the power supply must be secured so that the current required by the transmitter is sufficient for creating a reliable connection.
4. The antenna is installed according to manufacturers instructions.
5. The radio modem settings correspond to those of the terminal and all radio modems of the system are compatible and have the same settings.
6. The radio modems are on the same channel.
7. If the special RTS/CTS handshaking is used, make sure that in the reception RTS is in the "0"-mode (-12 V). RTS will turn on the radio transmitter in the "1"-mode. If the special RTS/CTS handshaking is not used the RTS line can be left unconnected.

APPENDIX 1.

The timing diagram of RS-232 interface of SATELLINE-2ASc radio modems

The timing of the data transfer is as follows if the special RTS/CTS handshaking is not in use:

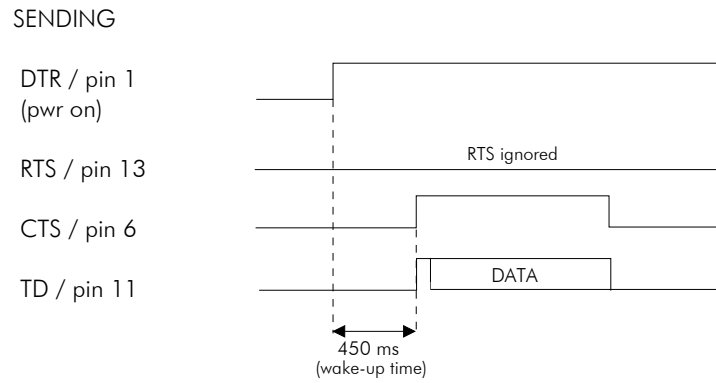

The timing of the data transfer using the special RTS/CTS handshaking is the following:

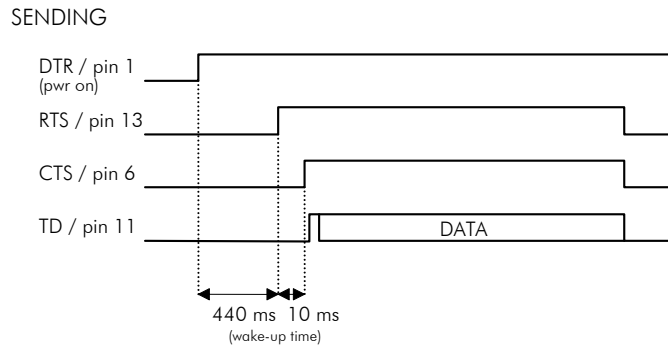

APPENDIX 2.

RSSI Signal

Received Signal Strength Indicator, RSSI, (D-connector pin 5) can be used for the approximate determination of the radio signal strength on the current channel.

In the following figure is typical RSSI voltage (V) as a function of the signal level (dBm). In practise signal level exceeds -25 dBm only if the distance to a transmitting modem is less than 10 meters.

